

SA400-2

product group: **Stage Performance**
system type: **Dual Direct Radiating 10"s + 2" HFD**

construction

The SA400-2 is a compact 2-way mid/high system in a trapezoidal, computer optimized enclosure. Loudspeaker compliment consists of twin proprietary midrange 10"s, individually loaded into separate sub-compartments, and a single 2" compression driver mounted on a constant directivity 70°x50° horn. The enclosure is constructed of durable 12-ply void-free birch laminate, dadoed for strength and durability. Perforated steel and acoustic foam is employed for frontal protection of the loudspeaker compliment.

Features:

- Designed to Array with other SA400-2
- 12-ply Dadoed Construction
- Durable ProCoat™ Elastomeric Finish

the idea behind it

The SA400-2 was designed as compact, multipurpose, dedicated mid /high range "workhorse" system for small to medium scale stage sound reinforcement duty. Its durable construction, compact size and high arrayability make this system ideal for small to medium size live performance sound reinforcement.

Applications:

- Live Club Installation
- Live Theater
- Rental P.A.

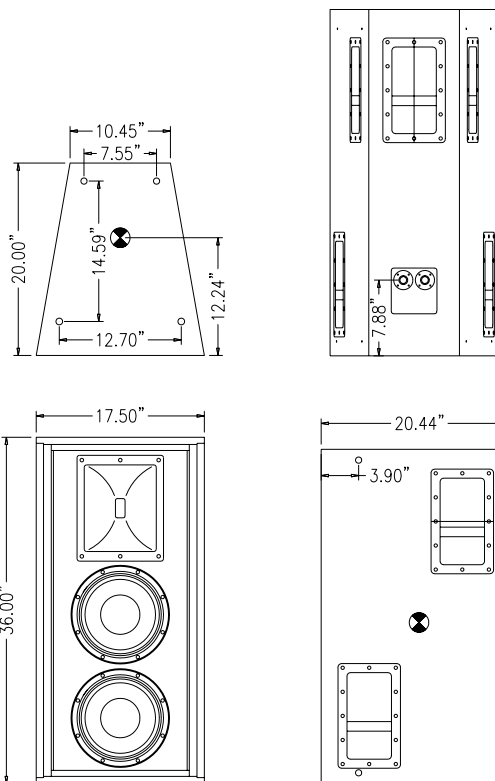

SA400-2



performance parameters

physical properties

power handling	750w RMS	weight	120lbs
frequency response	100Hz - 18kHz	dimensions inches	36H x 17.5w x 20d
nominal impedance	4Ω Mid 16Ω High	finish	ProCoat™
sensitivity	101db Mid 111db High	enclosure material	5/8" 12-ply
maximum output SPL	130db Continuous 136db Peak	construction	rabbet & dadoed
recommended crossover	125Hz / 1.6kHz	suspension	internal 3/8 th
directivity/coverage	70°x50° (HxV)	connectors	NL8
		transducers	(2) 10" Midrange (1) 2" HF Driver
		recommended LF	SA455