

TECHNICAL SPECIFICATIONS



ID2.112-SB

Product Group: iDESIGN Installation Group
System Type: Subwoofer, Single 12"

FEATURES & ADVANCES

- 14 Reinforced 3/8-16 threaded hang points
- Omni-mount locations on 4 sides
- U-Bracket factory hardware available
- Combines with other iDESIGN modules to form arrays

PRODUCT DESCRIPTION

The ID2.112-SB is a subwoofer designed for permanent installations. This high output foreground module features a direct radiating 12" cone loudspeaker. By combining iDESIGN™ modules in pre-engineered arrays, systems can be configured for larger venues.

MOUNTING & RIGGING

Mounting locations are distributed across 5 surfaces of the enclosure. Omni-mount™ compatible locations are available on 4 sides of the enclosure, while an additional 14 reinforced 3/8-16 threaded locations are available for other mounting options. iDESIGN iDB™ Series array frames are available to facilitate assembly and suspension of multiple modules as a single cluster. iDESIGN iDB™ Series U-bracket hardware is also available for single unit wall and ceiling mount installation.

CONSTRUCTION

The enclosure is constructed of 12-ply void-free birch hardwood plywood and is coated with a weather and wear resistant ProCoat™ polyurea hybrid finish. All rigging components are weather protected with a heat cured epoxy powder coat finish. Components in the front of the enclosure are protected by a curved grill made from perforated steel that is coated with heat cured epoxy powder, and lined with acoustically transparent foam.

AMPLIFICATION & PROCESSING

One channels of discrete amplification and signal processing are required for this module. The preferred signal processors for all iDESIGN products are the McCauley M Series family of digital processing units. The System Design Group can help in creating a complete amplification and signal processing solution.

APPLICATIONS

- Houses of Worship
- Performing Arts Centers
- Dance Clubs
- Theme Parks
- Auditoriums
- Theatrical Sound Design
- Live Clubs
- Sports Facilities



PERFORMANCE PARAMETERS

System Type	Subwoofer, Single 12"
Frequency Response -10dB +/- 3dB	35Hz - 1.2kHz 50Hz - 800Hz
Sensitivity LF	95dB @ 2.83V 1 m
Maximum SPL LF	(cont. / peak) 124dB / 130dB
Power Ratings LF - RMS	450w @ 8Ω
LF - AES	800w @ 8Ω

PHYSICAL PROPERTIES

Weight	65lbs / 29.48kgs
Dimensions inches centimeters	27.5 H x 15.3 W x 19.9 D x 5.1 T 69.8 H x 38.4 W x 50.6 D x 12.9 T
Enclosure Material	5/8" 12 ply Birch Laminated
Suspension	(14) 3/8-16 reinforced hang points (4) Omni-Mount™ compatible mounting locations (3) Horizontal U-Bracket mounting locations (1) Vertical U-Bracket mounting location
Finish	Procoat™ Polyurea-Hybrid Weatherproofing (Black is standard, White and / or Custom Colors Available)
Transducers	(1) 12" LF Transducer
Connectors	Barrier terminal strip
Compatible Array Frames (for building clusters)	IDB.828-AF, IDB.22-AF, IDB.222-AF, IDB.252-AF, IDB.282-AF, IDB.525-AF
Compatible U-Brackets (for deploying individually)	IDB.112-H, IDB.112-V

DIMENSIONAL ILLUSTRATIONS

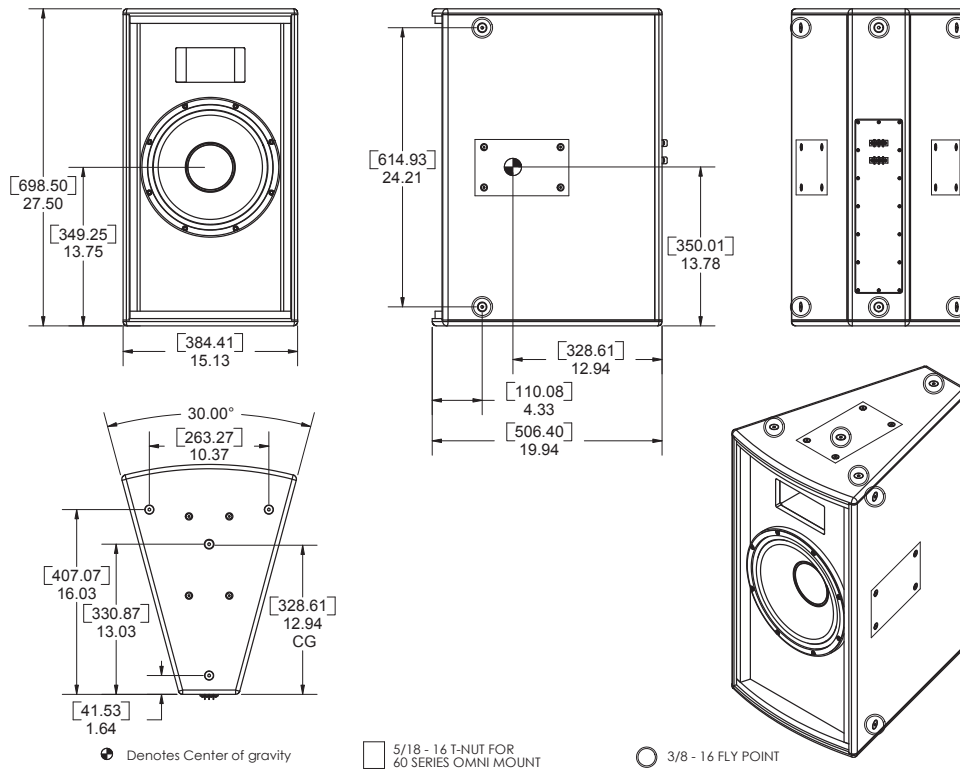

ARCHITECTS AND ENGINEERS SPECIFICATIONS

The low frequency loudspeaker system shall incorporate a single 4" (102 mm) voice coil, 12" (303 mm) diameter transducer, mounted in an optimally vented enclosure, and tuned for maximum low frequency response. The horizontal and vertical beam width for a single unit shall be the 360°. Directional characteristics can be achieved with an array of multiple cabinets.

The system frequency response shall vary no more than ± 3 dB from 45 Hz to 180 Hz measured on axis. The transducer shall produce a Sound Pressure Level (SPL) of 95 dB SPL at a distance of 1 meter with an electrical power input of 1 Watt, and shall be capable of producing a maximum peak output of 130 dB SPL on axis at 1 meter.

The low frequency transducer shall handle 800 Watts of amplifier power (per AES ref Standard AES2-1984-r2003) and shall have a nominal impedance of 8 Ohms.

The loudspeaker enclosure shall have a maximum weight of 65 lbs.(29.5 kg) and shall measure 15.13" (385 mm) wide at front, 5.16" (203 mm) in width at rear, 27.5" (699 mm) in height, and 19.94"(507 mm) in depth. The enclosure sides shall taper at 15° from a maximum frontal width, narrowing to the rear. The structure of the enclosure shall be constructed of 12-ply void-free birch hardwood plywood and shall have a weather and wear resistant ProCoat(tm) polyurea hybrid finish.

Input connectors shall be two, two-terminal barrier strips, each connector wired in parallel.

A total of fourteen 3/8"-18 UNC threaded mounting/suspension points (four on top, three on bottom, two per side and one back) shall be provided. Four additional mounting points shall be provided on the top, bottom, and each side configured to accept an OmniMount brand, Series 60 bracket.

Components in the front of the enclosure are to be protected by a curved grill made from perforated steel that is coated with heat cured epoxy powder, and lined with acoustically transparent foam.

The low frequency loudspeaker system shall be the McCauley Sound model iD2.112-SB.